



x1



x2



x2

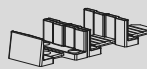

x1



x1

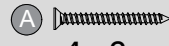

x4-x8



x4

30 kg

1

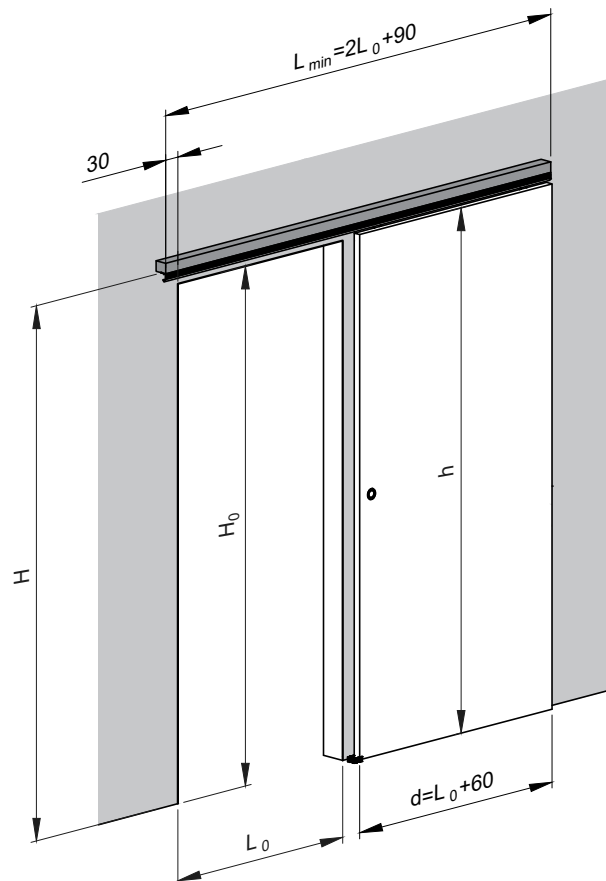
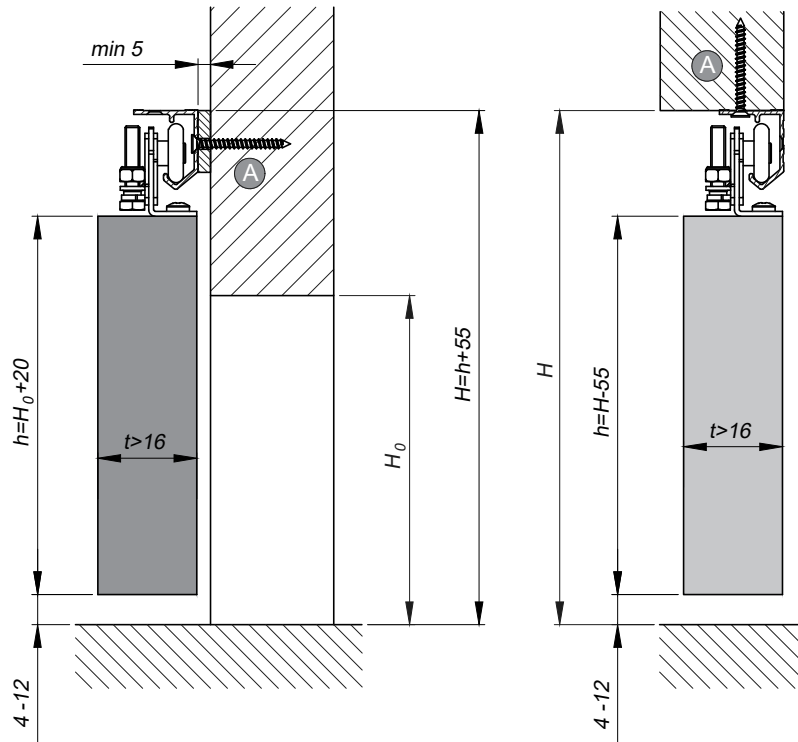

2

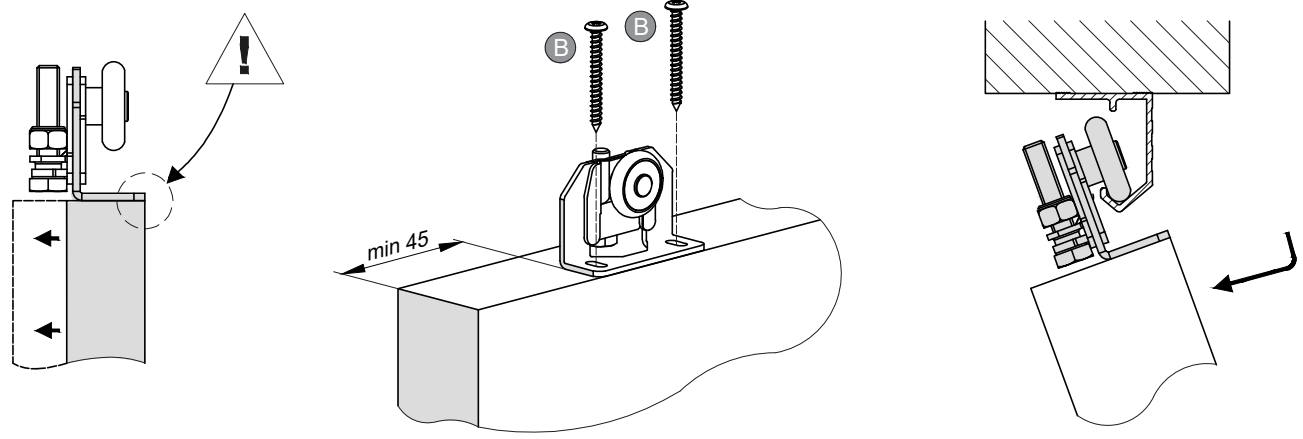

3

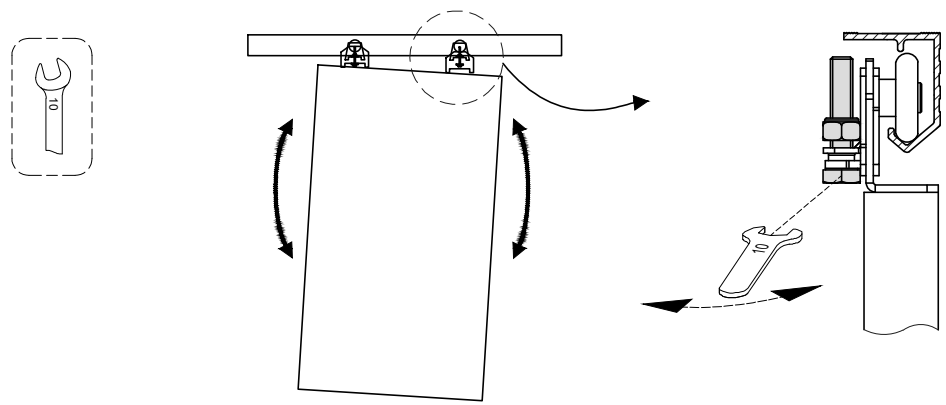

4

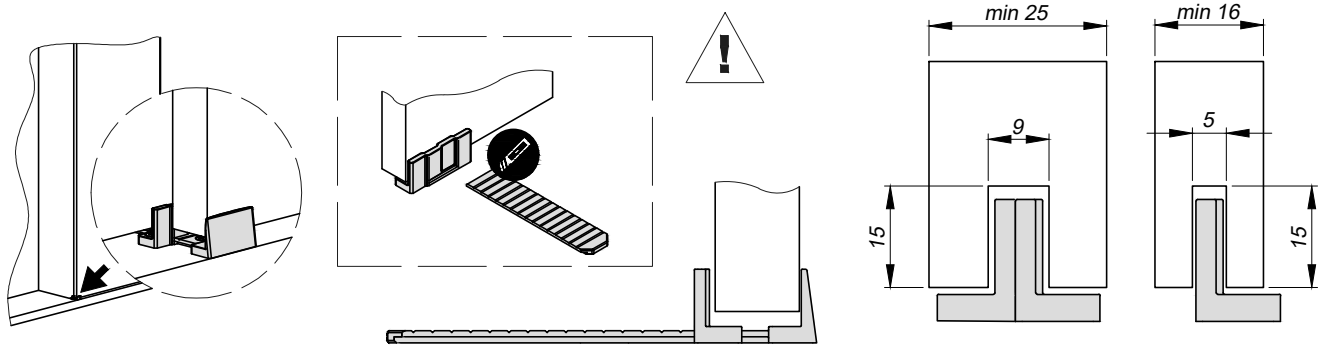

5

#2.5

